

# Mobile crane

# LTM 1070-4.2

Max. lifting capacity: 70 t

Max. lifting height: 65 m

Max. working radius: 48 m



# LIEBHERR

# Mobile Crane LTM 1070-4.2

## Flexible and immediately operational



A long telescopic boom, high capacities, an extraordinary mobility as well as a comprehensive comfort and safety configuration distinguish the mobile crane LTM 1070-4.2 from Liebherr. The 70-ton crane offers state of the art technology for more convenience for the practical operation.

- 50 m telescopic boom
- 16 m double swing-away jib, optional hydraulically adjustable
- 65 m hook height with telescopic boom extension and swing-away jib
- 48 t total weight incl. 10.7 t counterweight and swing-away jib at 12 t axle load
- Great operational flexibility due to top capacities with full and partial counterweights
- Chassis width 2.55 m with tyres 16.00 R 25
- Active, speed depending rear axle steering
- Air operated disk brakes





#### Drive train

- 6-cylinder Liebherr turbo diesel engine  
270 kW/367 HP at 2000 rpm, max.  
torque 1700 Nm at 1100 - 1500 rpm
- Automated ZF-gearbox AS-TRONIC,  
12 forward-, 2 reverse speeds
- 2-stage transfer gearbox,  
crawl speed 0,53 km/h
- Axles 3 and 4 driven, optional axle 1

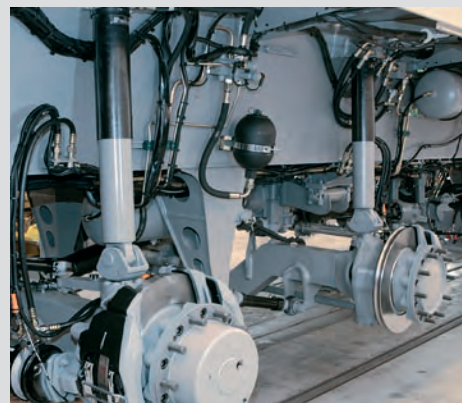

# Most modern chassis and drive technology

## High mobility and efficiency

A high performance 6-cylinder Liebherr turbo diesel engine with 270 kW/367 PS provides for dynamic driving performance. The 12-speed ZF-gearbox with automatic gear change system AS-TRONIC grants high efficiency and best comfort.

- Reduced fuel consumption due to high number of gears and high degree of efficiency of the dry clutch
- Best manoeuvrability and minimum crawl speed by means of the 2-stage transfer gearbox
- ABV - automatic blocking preventer with ASR anti-slip control

## Compact, mobile and weight optimized

Due to its extreme compact design the LTM 1070-4.2 can also manoeuvre on the tightest job sites.

- Chassis length only 10.43 m
- Minimum turning radius only 8.17 m
- Chassis width only 2,55 m, even with tyres 16.00 R 25
- Tail swing only 3.46 m

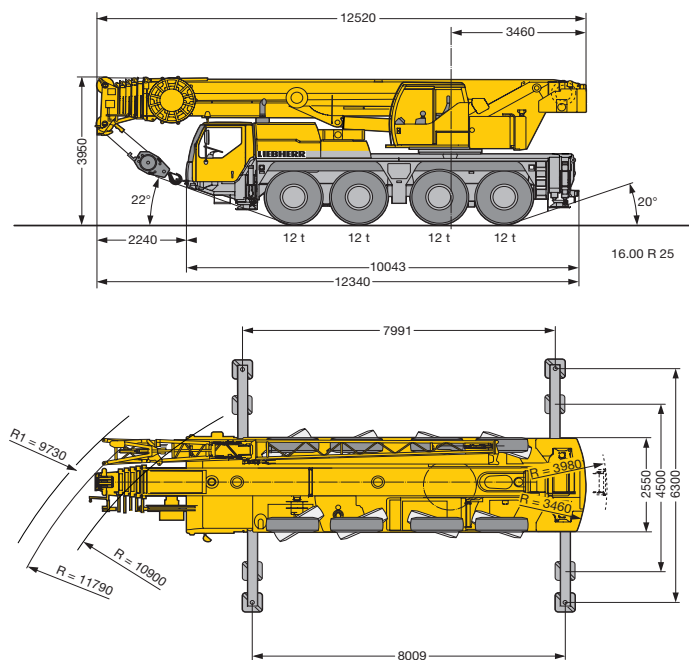

### Hydro pneumatic axle suspension „Niveaumatik“

- Maintenance free suspension cylinders
- Heavy layout for axle loads up to 40 t
- Spring travel +100/-100 mm
- High side stability at cornering
- Choice of the driving conditions by fix programs



### Air operated disk brakes

- Higher braking power, better brake control
- Improved track stability
- No brake fading at higher operation temperatures
- Higher service life
- Shorter working time for changing of the brake pads
- Brake pads with wear indicators



### 5 Steering programs

- Program selection by simple push button
- Clear arrangement of the control elements and displays
- Programs changeable during driving
- Crab steering controlled comfortably by the steering wheel

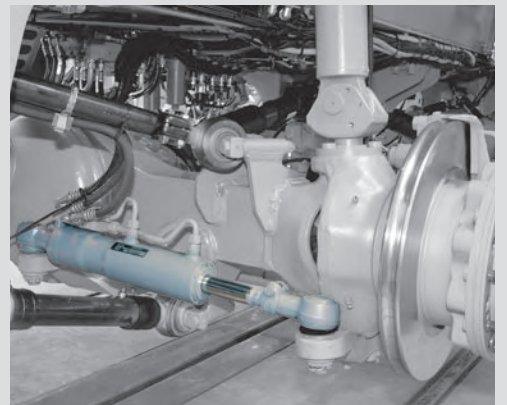

# Variable steering concept



## Active rear axle steering

The rear axles are electro-hydraulically actively steered depending on the speed and the steering angle of the front axles.

5 steering programs (P) are preselectable by push button.

- Distinct reduction of the tyre wear
- Improvement of the manoeuvrability
- Stable driving performance also at high speeds
- All 4 axles steerable

## High safety standards - complete know-how from Liebherr

- Centring cylinders for automatic straightening of the rear axles in case of failure
- Two independent hydraulic circuits with wheel driven and engine driven hydraulic pumps
- Two independent control computers

### P1 Road steering

The axles 1 and 2 are mechanically steered by the steering wheel. The axle 4 is actively steered depending on the speed and on the steering angle of the front axle. Above 30 km/h it will be adjusted to straight driving and fixed. Axle 3 is none steered for road driving.



### P2 All-wheel steering

The axles 3 and 4 are turned by the steering wheel depending on the steering angle of the front axle to provide for the smallest turning radius.



### P3 Crab steering

The axles 3 and 4 are turned by the steering wheel to the same direction as the steering position of axle 1 and 2.



### P4 Reduced swing out

The axles 3 and 4 are turned depending on the wheel turn of the front axles to minimize the back swing of the rear of the chassis.



### P5 Independent rear axle steering

The axles 1 and 2 are steered by the steering wheel, the axles 3 and 4 are steered by push buttons independently from the steering angle of the axles 1 and 2



### Centring cylinders at the rear axles

- Automatic straight positioning of the rear axles in case of failure.



#### The driver's cab

- Corrosion resistant steel plate execution, cathophoretic dip primed
- All around safety glazing
- Tinted windows
- Heatable and electrically adjustable mirrors
- Air cushioned driver's seat with lumbar support



# Comfort and functionality

## Modern driving cab and crane cab

The modern driving cab as well as the backwards tiltable crane cab offer a comfortable and functional working environment. The control elements and displays are arranged according to ergonomic factors. Thus a safe and fatigue-proof working is assured.

## Fast and safe erection

The supporting, the counterweight assembly as well as the mounting of the additional equipment are designed for speed, safety and comfort. For the safety of the operating staff pedestals, hand holds and railings are provided.



### Crane supporting – fast, comfortable and safe

- BTT - Bluetooth Terminal, mobile control and display device
- Electronic levelling display
- Fully automatic levelling by push button
- Engine-start/stop and speed regulation
- Lighting of support area with 4 integrated floodlights
- Stroke of supporting cylinders front 650 mm, rear 700 mm
- Outriggers 1-stage, fully hydraulic, low maintenance extending system

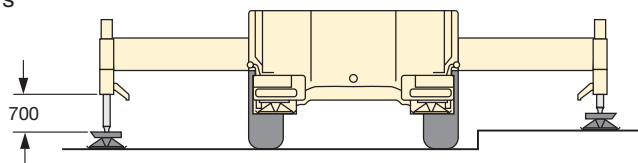

### The crane cab

- Corrosion resistant, galvanized steel plate execution, powder-coated
- All around safety glazing
- Tinted windows, front screen can be opened
- Skylight with bullet proof glass
- Crane driver's seat with lumbar support
- Sidewise extendable running board
- 20° tiltable to the rear



**Hydraulic assembly support for attachment of the swing-away jib with BTT**

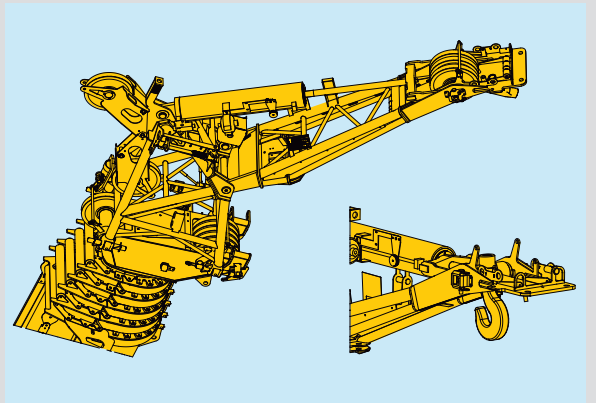

**Assembly jib with hook traverse**

# High lifting capacities and flexible boom system

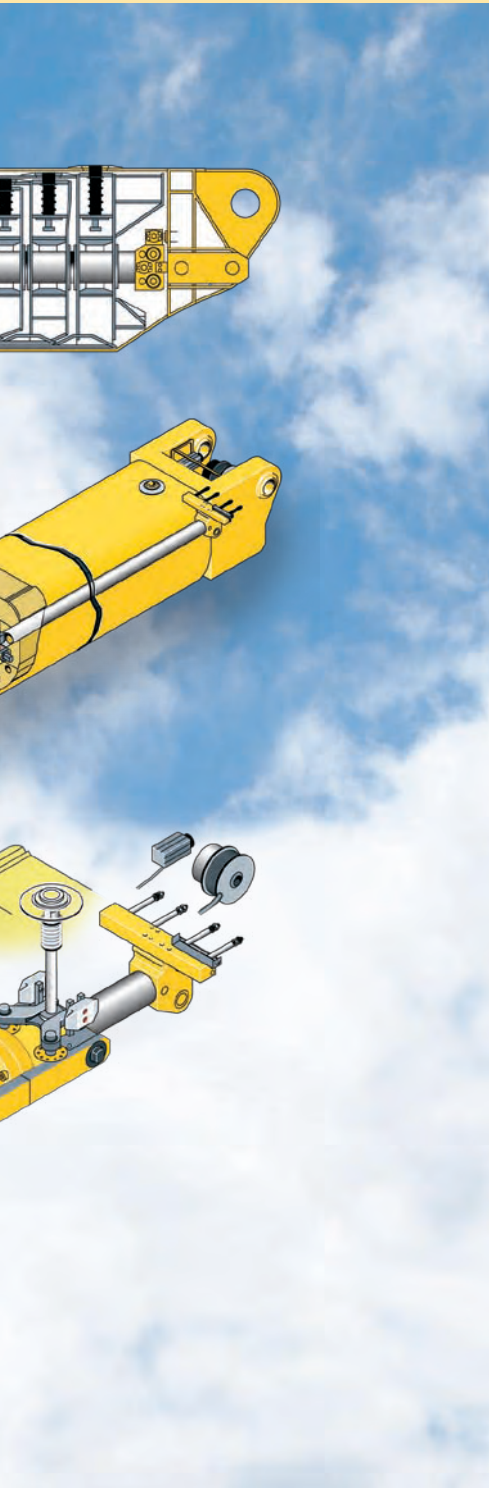

## Powerful, long telescopic boom and functional lattice extensions

The telescopic boom consists of the base section and 5 telescopic sections, which can be comfortably and automatically extended and pinned to the requested length by the thousand fold proven single cylinder telescoping system TELEMATIK.

- 50 m long telescopic boom
- 9.5 m – 16 m long double swing-away jib, attachable at 0°, 20°, 40° and 60°
- Hydraulic adjustment of the swing-away jib at full load from 0° to 60° (optional), interpolation of capacities
- Rooster sheave, foldable sidewise
- 3.2 m long assembly jib, consisting of the swing-away adapter and an additional set of sheaves or a hook traverse.

## High capacities with full counterweight as well as with partial counterweight offer a wide application of operations

- High lateral stability due to the oval boom profile
- Optimized capacities due to the numerous extension variations
- Capacity 6.7 t at 50 m long telescopic boom

## High capacities at the unpinned telescopic boom

- High telescopic capacities due to interpolation.
- Separate charts for holding of loads at unpinned telescopic lengths
- Display at LICCON monitor

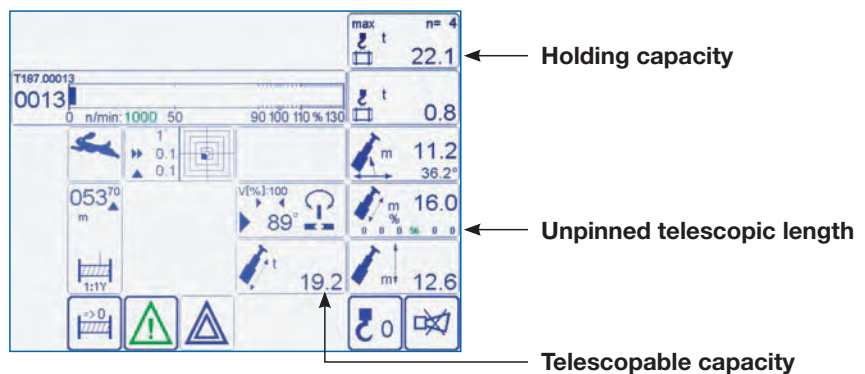

3,2 m long assembly jib

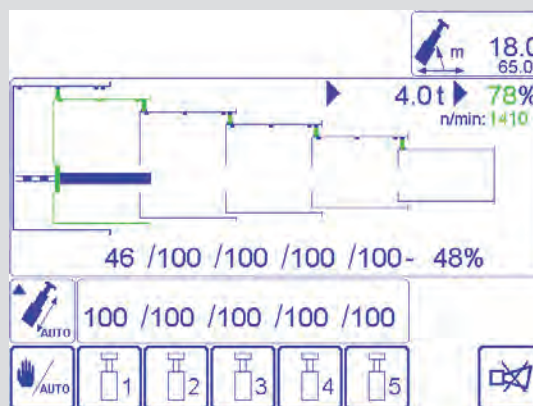

## The fully automatic telescoping system „TELEMATIK“

- Improvement of capacities at long booms and large radii due to light-weight telescoping system
- 1-stage hydraulic cylinder with hydraulically operated drive pin
- Maintenance free telescoping
- Telescoping fully automatic
- Simple operation, supervision of telescoping at the LICCON monitor

# Variable counterweight

## Mounting of counterweight - only a matter of minutes

- Multitude of counterweight variations from 5.7 t to 14.5 t
- Fast ballasting with keyhole-technology from the crane cabin
- Compact counterweight dimensions, at 14.5 t counterweight only 2.55 m counterweight width
- Tail swing only 3.46 m
- 48 t total weight including 10.7 t counterweight and double swing-away jib at 12 t axle load

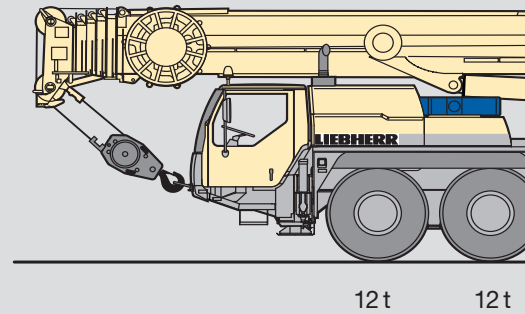

### The hoist gear

- Hoist winch with internal planetary gear and spring loaded multi disk brake.
- Rope pull 57 kN at the outer layer
- Max. rope speed 125 m/min
- 2. hoist gear optional



# Powerful crane drive

## With proven components

The drive components for the crane operation are designed for high performance and provide for sensitive and precise handling of the load. They are specially tuned for the crane operation and proved in severe long-term tests.

- Crane drive from diesel engine in chassis
- Optimized fuel consumption by electronic engine management
- Diesel-hydraulic crane drive, open hydraulic circuits with electric „LOAD SENSING“-control, 4 working motions simultaneously possible
- Electric/electronic SPS-crane control via the LICCON-computer system
- Comfortable armrest controls with 2 self-centering 4-fold multifunctional joysticks, stepless control of all crane motions, with winch and slewing gear indicators
- Slewing gear standard reversible from open to hydraulically locked, so the slewing motion can be optimal adapted for the different operation conditions, e. g. sensitive for installation work or fast for cycle work

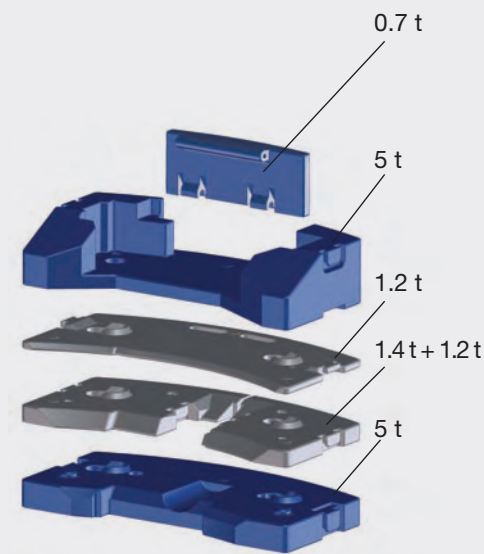
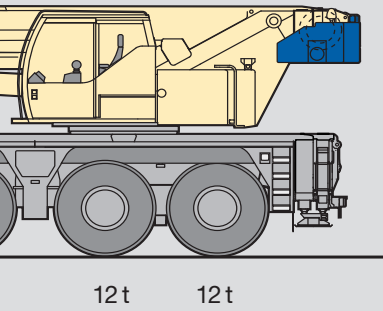

Basic counterweight    10.7 t  
Additional counterweight    3.8 t  
**Total**                    **14.5 t**

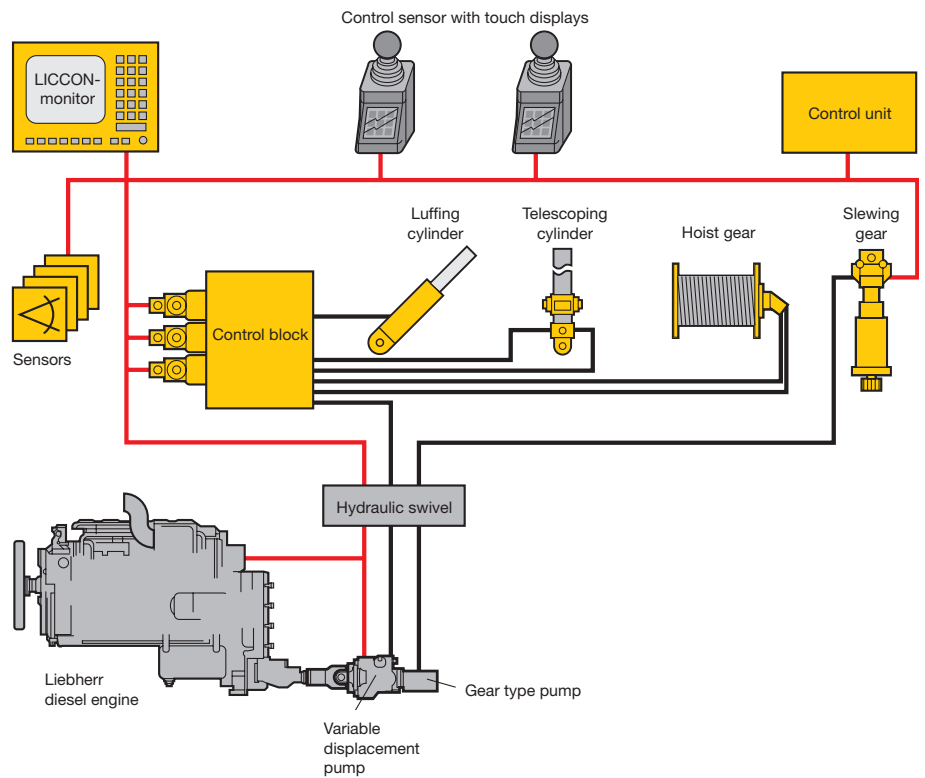

### The slewing gear

- Planetary gearbox, spring loaded multi disk brake
- Reversible open or hydraulically locked as standard
- Slewing speed from 0 to 1.5 min<sup>-1</sup> infinitely variable
- 6 stages between 15 % and 100 % preselectable



### The central greasing

- Standard central greasing device for slewing bearing, boom bearing, luffing cylinder and winch bearing
- Even supply of grease
- Filling quantity visible at any time in transparent reservoir



LICCON  
 DSE-TESTSYSTEM - VERSION 00.00  
 (c) LIEBHERR-WERK EHINGEN 2008

LTM 1070-3.1/185 -U  
 003268/0101 2008-06-02 12:06  
 MEST 10:48:25 2008-06-11

GRAM: 000083251  
 OVRT: V01.38.10  
 10.8.57.100

> SPRACHE: DEUTSCH <

SYSTEM FEHLER UHR SCREEN SHOTS SERVICE EDIHE

### The LICCON test system

- Fast locating of failures at the computer screen without measuring equipment
- Display of failure codes and failure descriptions
- Comfortable dialog functions for supervision of all in and out terminals
- Display of functions and allocation of sensors and actors

# Intelligent crane control

## For functional and safe crane operation, the LICCON-computer system

The soft- and hardware of the mobile crane control is developed by Liebherr in house. The central point is the LICCON-computer system (Liebherr Computed Controlling). The system undertakes extensive information, control and supervision tasks. The control components have proved themselves in the diverse climate conditions worldwide.

## LICCON erection and operation program

- Operation programs:
  - Overload limiter (LMB)
  - Erection program with erection display
  - Operation program with operation display
  - Telescoping program with telescoping display
- Setting up of the erection status by comfortable dialog functions
- Display of all important data with graphic symbols
- Reliable cut-off at exceeding of the permissible load moments
- Winch display for exact hoisting/lowering of the load within centimetres

## The data bus technology

Liebherr mobile cranes are completely linked through the data bus system. All important electric and electronic components are equipped with own microprocessors and communicate over only a few data cables. For the special requirements of the mobile cranes Liebherr has developed its own bus systems (LSB-Liebherr-System-Bus). The data bus system technology improves the reliability, the comfort and the safety of the drive and crane operation:

- Higher reliability due to much less electric cables and contacts
- Continuous self testing of the „intelligent sensors“
- Extensive diagnosis possibilities, fast fault finding

### The LICCON working range limiting system (optional)

- Relief for the crane driver by automatic supervision of the working range boundaries like bridges, roofs etc.
- Simple programming
- Four different limiting functions:
  - Boom head height limiting
  - Radius limiting
  - Slewing angle limiting
  - Border limiting

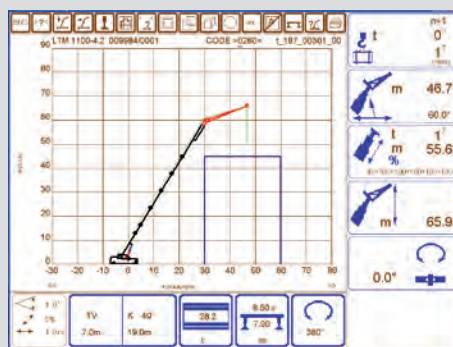

### The LICCON working planner (optional)

- Computer program for planning, simulation and documentation of crane operations at the computer
- Display of all load charts belonging to a specific crane
- Automatic search of a suitable crane by input of the load case parameters load, radius and hoisting height
- Simulation of crane operations with drawing functions and display of support forces

# The new control generation - LICCON2



The new generation of the Liebherr crane control offers extended customer benefits and higher operational comfort by additional possibilities of use. The base for this is the modern and future oriented control architecture with components, which are optimized regarding the computing power as well as their capacities.

## Wireless remote control (optional)



## Attaching and detaching of the hook block

The BTT – Bluetooth terminal – offers the crane driver the possibility to attach the hook block to or detach it from the front bumper within sight by remote control of the hoist winch and the luffing cylinder of the telescopic boom.

## Supporting the crane

By use of the BTT the mobile crane can be comfortably and safely supported on the outriggers. Engine start/stop, speed regulation, electronic level display and automatic support leveling are available as standard. Optionally also the supporting forces can be displayed on the BTT.



## Colour monitor

The readability of the data on the monitor of the LICCON2 control system in the crane cab is enhanced by the colour display. Warnings and crane utilization are considerably better recognized.



## Touch-Displays

Below the joy sticks integrated in the armrests the touch displays are installed, with which the various operational functions can be selected. This are beside others the drive and steering programs of the chassis, the axle suspension, the supporting of the crane, the adjustment of the working floodlights as well as heater and air condition controls.